

**PARALLEL ARM(PUSH SIDE) Mounting  
LEFT HAND DOOR SHOWN**

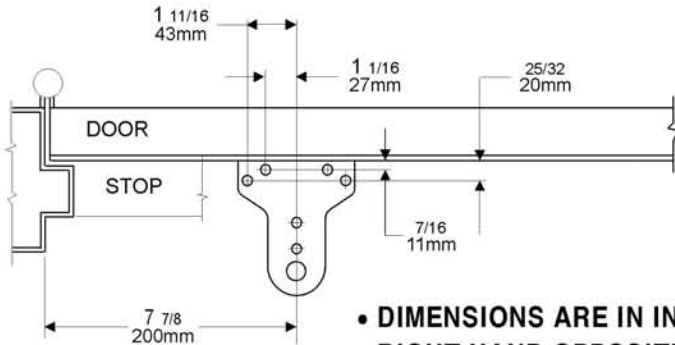

- DIMENSIONS ARE IN INCHES
- RIGHT HAND OPPOSITE
- DO NOT SCALE

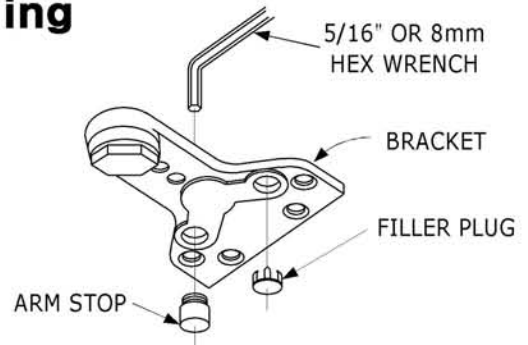

**DOOR CLOSER ADJUSTMENT**

- L: LATCH SPEED VALVE
- C: CLOSING SPEED VALVE
- B: BACKCHECK VALVE

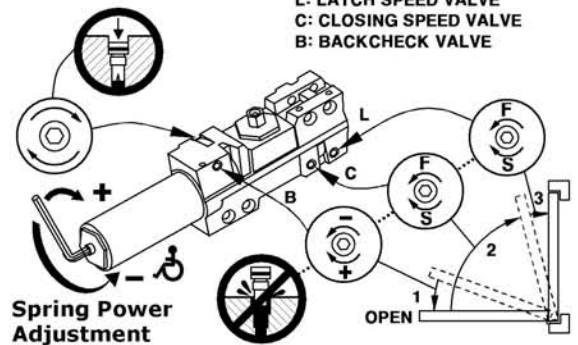

**Power Adjustment Chart**

CLOSER SIZE	1	2	3	4	5	6
CLOCKWISE TURNS	-6	-3	SET	3	7	12

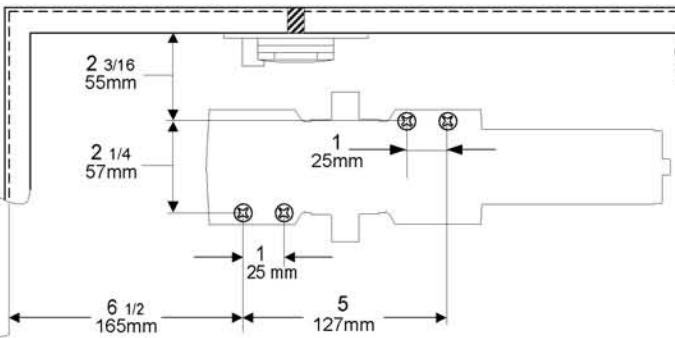

**PARALLEL ARM(PUSH SIDE) Mounting  
RIGHT HAND DOOR SHOWN**

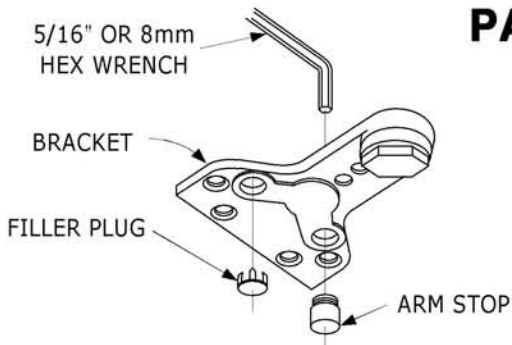

- DIMENSIONS ARE IN INCHES
- LEFT HAND OPPOSITE
- DO NOT SCALE

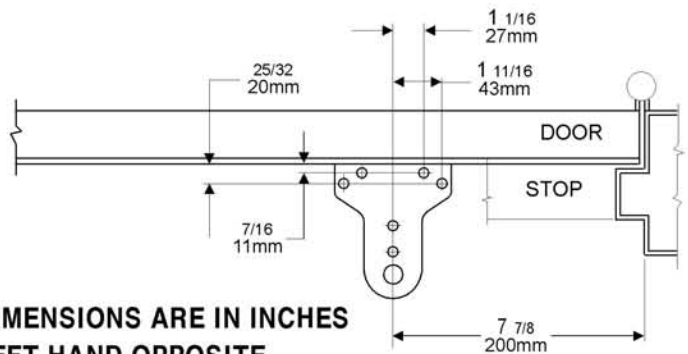

**DOOR CLOSER ADJUSTMENT**

- L: LATCH SPEED VALVE
- C: CLOSING SPEED VALVE
- B: BACKCHECK VALVE

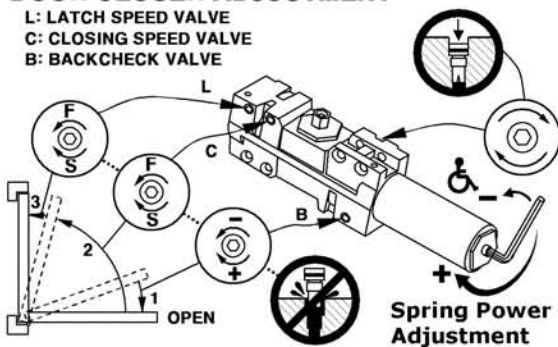

**Power Adjustment Chart**

CLOSER SIZE	1	2	3	4	5	6
CLOCKWISE TURNS	-6	-3	SET	3	7	12

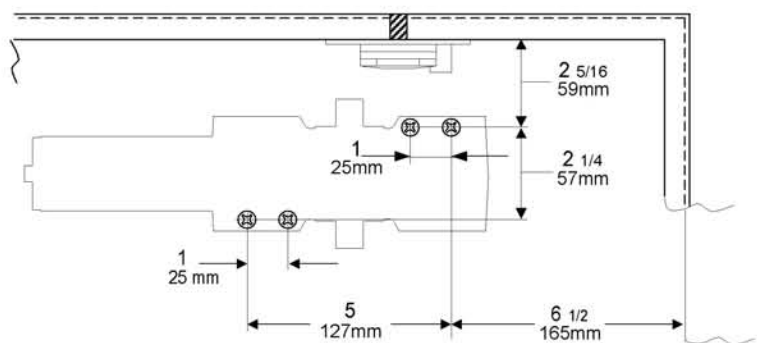

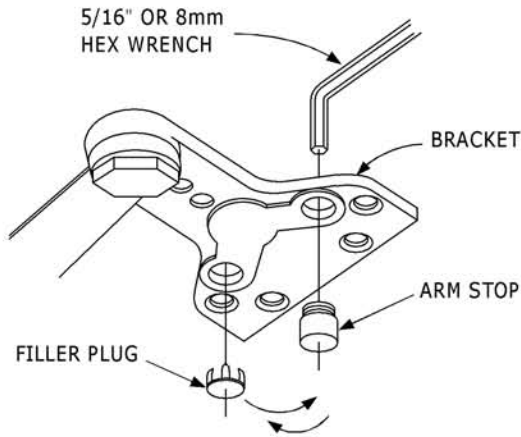

INTERCHANGEABLE FOR DOOR HANDING

THE HAND MUST BE CORRECT BEFORE THE BRACKET IS MOUNTED TO THE DOOR STOP(TOP JAMB).

Refer to page 1.

**FOR LEFT HAND DOORS**

All brackets are shipped assembled for LEFT HAND DOOR. Insert 5/16" (8mm) hex wrench into ARM STOP and turn anti-clockwise to seat as tightly as possible. Push filler plug in firmly.

**FOR RIGHT HAND DOORS**

Pull filler plug out of bracket. Using a 5/16" (8mm) hex wrench turn ARM STOP clockwise to remove form bracket insert in hole marked "R". Turn hex wrench clockwise to seat ARM STOP as tightly as possible. Push filler plug into other hole.

**INSTALLATION SEQUENCE**

LEFT HAND DOOR SHOWN – RIGHT HAND DOOR OPPOSITE

**CAUTION**  
 IMPROPER INSTALLATION OR REGULATION  
 MAY RESULT IN PERSONAL INJURY OR  
 PROPERTY DAMAGE FOLLOW ALL  
 INSTRUCTIONS CAREFULLY.

1. Adjusting spring power to match door width or weight as indicated by Power Adjustment Chart shown on page 1.
2. Mount closer on door to dimensions shown on page 1.
3. Attach MAIN ARM as follows.
  - (a) Remove stud at junction between MAIN ARM and FORARM
  - (b) -IMPORTANT-place open end wrench (spanner) on bottom shaft and turn toward hinge edge about 30°
  - (c) Place MAIN ARM on top shaft parallel with door and secure with shaft screw with wrench
4. Attach BRACKET to door stop (Top jamb) as shown on page 1.
5. Swing door open about 30° join main arm and forearm insert stud and tighten securely.

**IMPORTANT REMARKS**

**REGULATION**

Do not allow door to slam into frame. A normal standard closing time from 90° open position is 5 to 7 seconds evenly divided between main closing (sweep) speed and latching speed Adjust the CLOSING speed first, then adjust the LATCHING speed.

For slow closing speed of door turn speed adjusting valve of "C" (closing speed) clockwise and anti-clockwise for fast. Latching speed control of door is the same manner as closing speed adjustment.

**ADJUSTABLE BACK CHECK FUNCTION**

This function is essential to the proper operation of the SUPER RIGID PARALLEL ARM. Use just enough to prevent arm to striking stop with impact. See page 1.

**ATTACH COVER**

Slide cover insert into un-used cutout in cover. Install cover securely using screws provided.

**HOW TO HOLD-OPEN (90° STOP)**

A quarter turn on the HOLD-OPEN CONTROL HANDLE engages or disengages hold-open.

